

# EDGETEQ S-200

**Serious entry-level class with strong features.**  
Perfect for reliable edge gluing.





# Perfect edges produced with flexible machines for demanding customers

Individual customer requirements, sophisticated products and a wide range of materials — these are all factors that play a key role in today's wood processing sector. Therefore, it is important that production is flexible and efficient, especially in woodworking shops and for medium-sized businesses.

HOMAG offers you unbeatable advantages, has an international production network as well as sales and service companies, with a presence in more than 100 countries and around 7000 employees. HOMAG can help make your business competitive and ensure lasting business success. In short:

## YOUR SOLUTION

[MORE AT HOMAG.COM](https://www.homag.com)



## CONTENTS

- 04 The most important features
- 05 Edge parameters
- 10 easyTouch control systems
- 11 Our unit modules
- 22 Technical data
- 26 Life Cycle Services



## Seven models plus extensions — the choice is yours

### THE MOST IMPORTANT FEATURES.

The extensive equipment makes this series stand out: for example, PUR top roll pressure rollers for precise workpiece guiding, as well as optimized trimming tools for optimum chip removal and perfect processing quality. In addition, all machines can be extended.

Additional units such as scrapers or buffing units can be set up on specific machines with empty slots.

Machines in the HOMAG EDGETEQ S-200 series are energy efficient and environmentally friendly.

- **High-quality furniture with high-quality edges**
- **More output due to high availability**
- **Low energy requirements**
- **High levels of efficiency**
- **Optimum price/performance ratio**

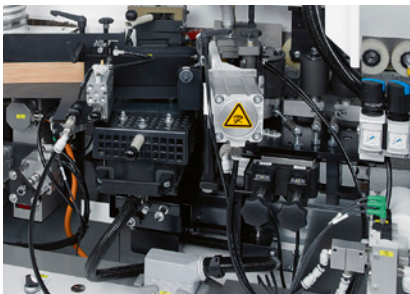

#### Gluing units for safe hot-melt glue application

HOMAG gluing units are ideal for quick, solid gluing. The heated gluing roller ensures an optimal adhesive temperature.

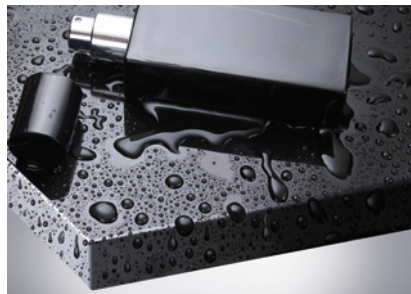

#### Edge gluing with PUR

At HOMAG, PUR glues are processed on the same machines and with the same application unit as EVA hot-melt glues.

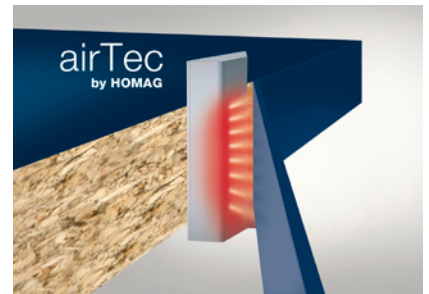

#### Zero joint technology with HOMAG airTec

Simple integration into the magazine in addition to the classic glue application with gluing roller. Available on the 1110 AT, 1120 AT and 1130 AT model.

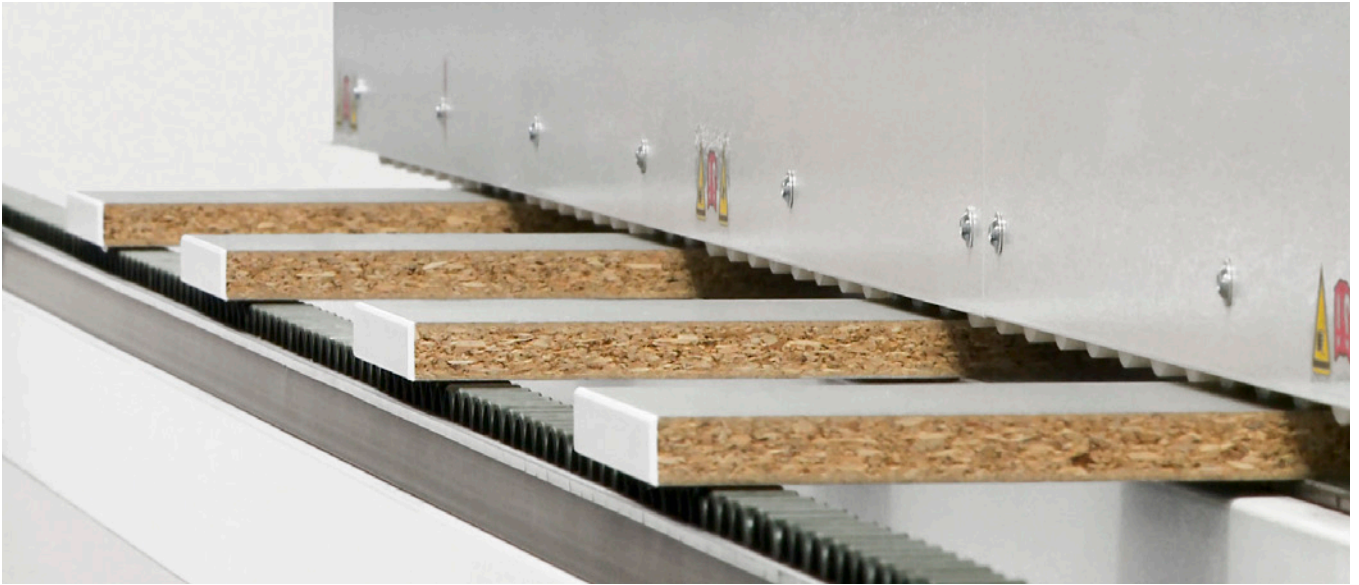

## Material types | Edge parameters

A high level of flexibility is achieved through the processing of all types of edge materials: 0.3-mm melamine, 2-mm ABS/PVC, 6-mm solid strip and veneer. Special tracing elements are ideal for processing sharp-angled or blunt-angled parts or parts with hinge holes.

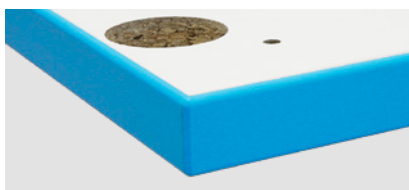
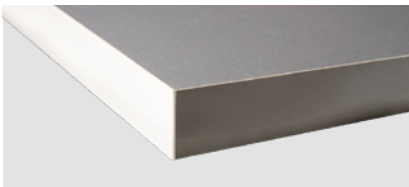

		a	b	c	d
	<b>SOLID</b> (mm)			0.4–3.0 (6.0)*	
	<b>ROLLERS</b> (mm)	for b = 22: min. 70	8–60	0.3–3.0	45/65
	<b>STRIPS</b> (mm)			0.4–3.0	

\* On the 1130 FC model



## Our solution for your requests

If you are new to mechanical edge processing, you have come to the right place. Intuitive operation, initial automation and flexibility in the equipment are the hallmarks of the compact edge banding machines of the EDGETEQ S-200 series.



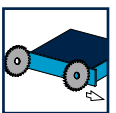
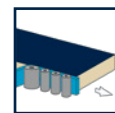

## EDGETEQ S-200 — Model 1130 FC

This machine offers a smart solution at an entry-level price point, specially designed for woodworking shops. A joint trimming unit prepares the edge to create an optimal joint. The precise gluing station features a special coating that also allows easy processing of PUR adhesives. The automatic fixed length magazine is equipped for a secure supply of material. The magazine can be used for rolls of material and for strip material. The snipping unit, which has two motors, guarantees a precise cut and the best results with an easily adjustable pneumatics system. The impressive trimming unit can be

simply adjusted between radius, chamfer and flush miller modes. In addition, there is a profile trimming unit for complete processing of workpieces, including corner processing. The finishing area has three units, which are equipped with a pneumatically adjustable profile scraper with quick-change heads, a glue joint scraper and a buffing unit. The special feature in this performance class: three post-processing units in the finishing area operating alongside a profile trimmer. This guarantees full flexibility in the post-processing of workpieces.



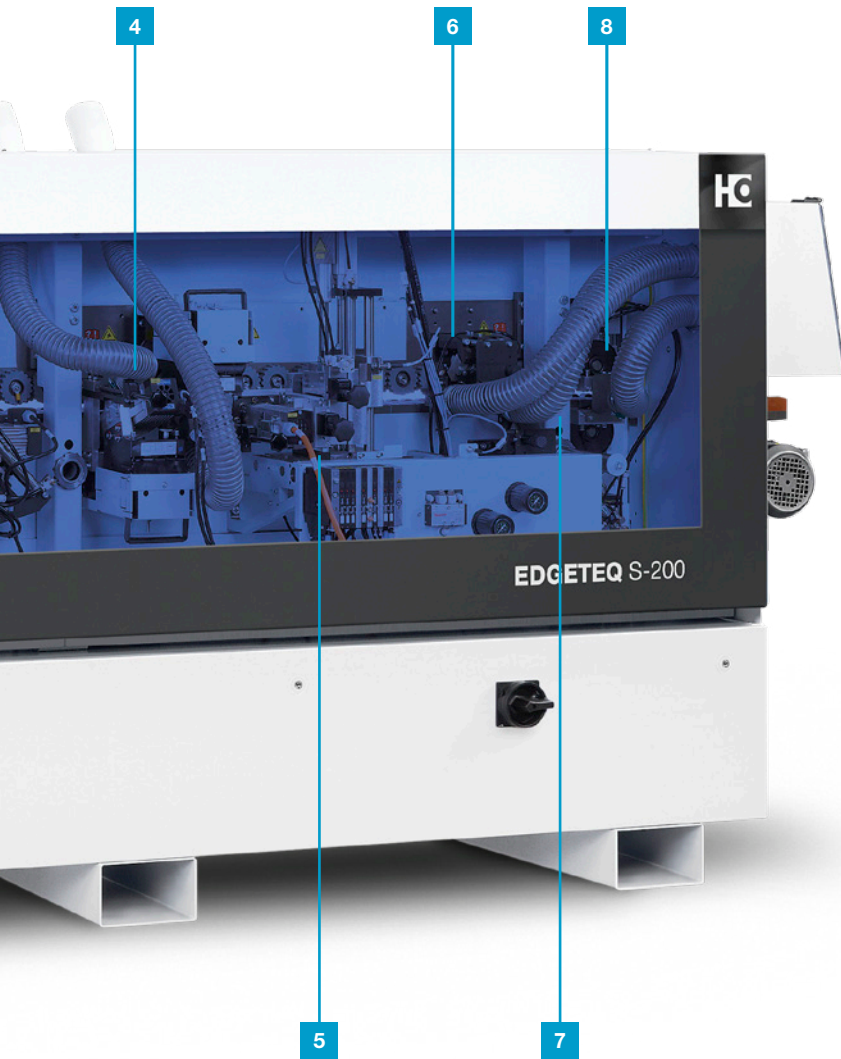

**6-mm edge thickness**  
for solid wood strips

Available on the 1130 FC model

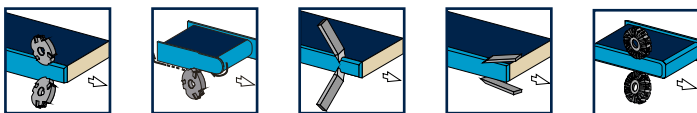

**1** Joint trimming unit

**2** Gluing unit

**3** Snipping unit

**5** Trimming unit

**5** Profile trimming unit

**6** Profile scraper

**7** Glue joint scraper

**8** Buffing unit



## easyTouch — Simple touches with effective results

The easyTouch control system embodies a new generation of operating systems. Simple touches on the touchscreen

interface guarantee fast navigation combined with a high level of easy operation.

### The benefits

- Clear 7" graphic display provides optimum control via touching the control panel directly
- 20 storable programs guarantee flexibility when processing a wide variety of edge materials and changing customer requirements
- Production readiness displayed by traffic light indicator
- Ability to adjust units quickly thanks to direct access via ctrl keys
- Intuitive, user-oriented navigation
- Clear overview of the help and assistant functions, including the glue pot temperature or troubleshooting in plain text

Betriebsdatenerfassung		1. 2mm ABS	
Stunden Gesamt	h	1274:00.00	X
Werkstücke Gesamt	Stück	446842	
Kantenlänge Gesamt	m	384521	
Stunden	h	0:45.00	Reset
Werkstücke	Stück	280	Reset
Kantenlänge	m	233.50	Reset

The operating hours for each commission are recorded accurately thanks to state-of-the-art operating data acquisition.

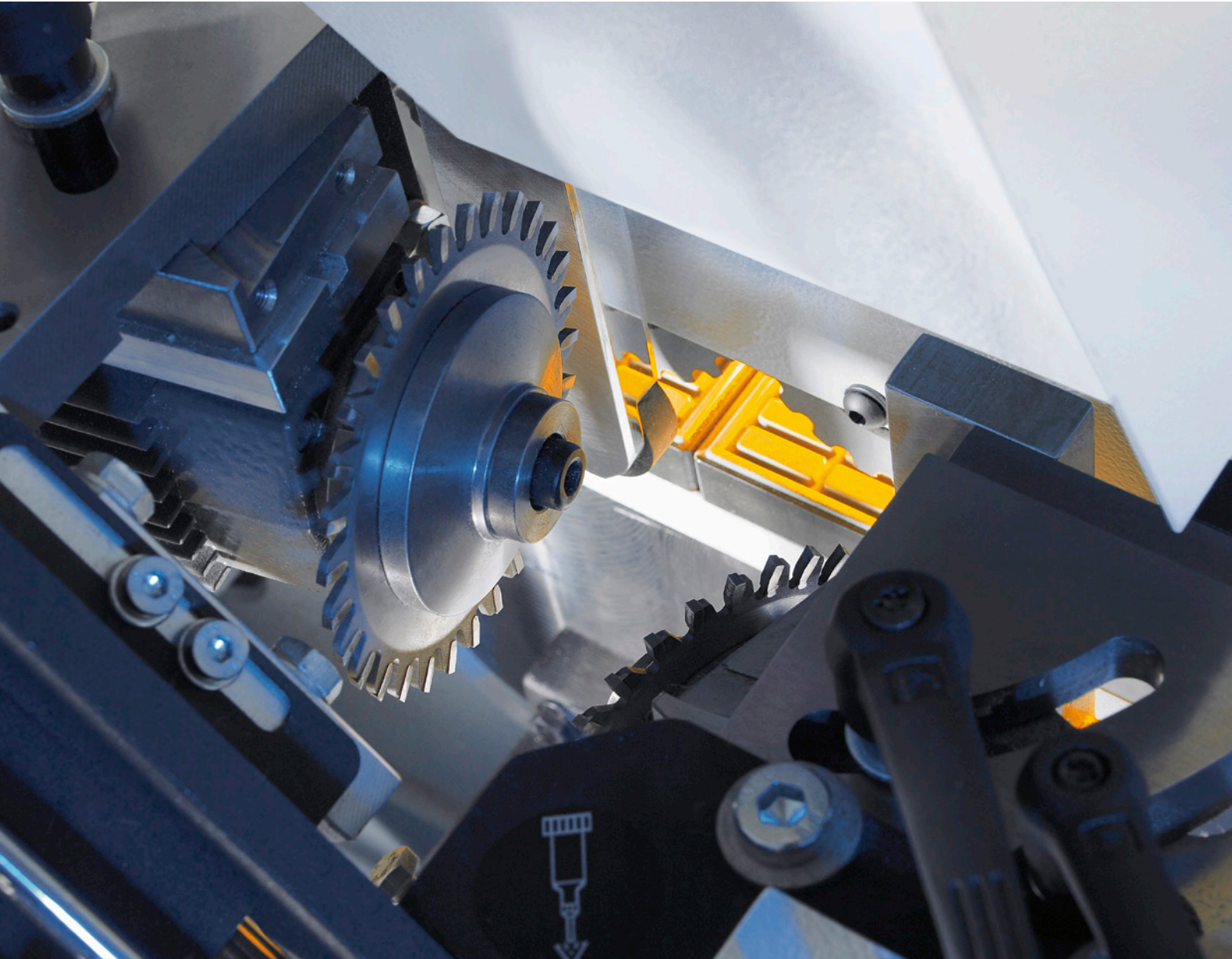

## Our unit modules: The right solution, whatever the requirement

For wide-ranging and diverse processing tasks, we use units from our tried-and-tested unit modules. We are constantly expanding our functions so we can offer you the right solution for new trends. The following pages contain units from the

fields of joint trimming, gluing, cutting, profile trimming and finishing. You benefit from a high level of precision and state-of-the-art technology, and the ability to produce your products flexibly and efficiently.

## Sprayers

Sprayers improve the edge quality during the entire processing. Separating agents prevent hot-melt glue residues forming deposits. The adhesive residues can be easily

removed using cleaning spray. Lubricants prevent shiny marks on the workpieces and protect sensitive surfaces before trimming.

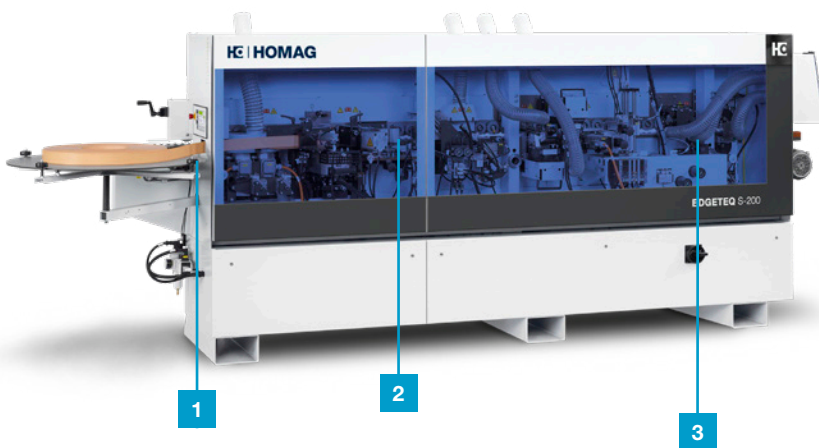

- 1** Separating agent
- 2** Lubricant
- 3** Cleaning agent

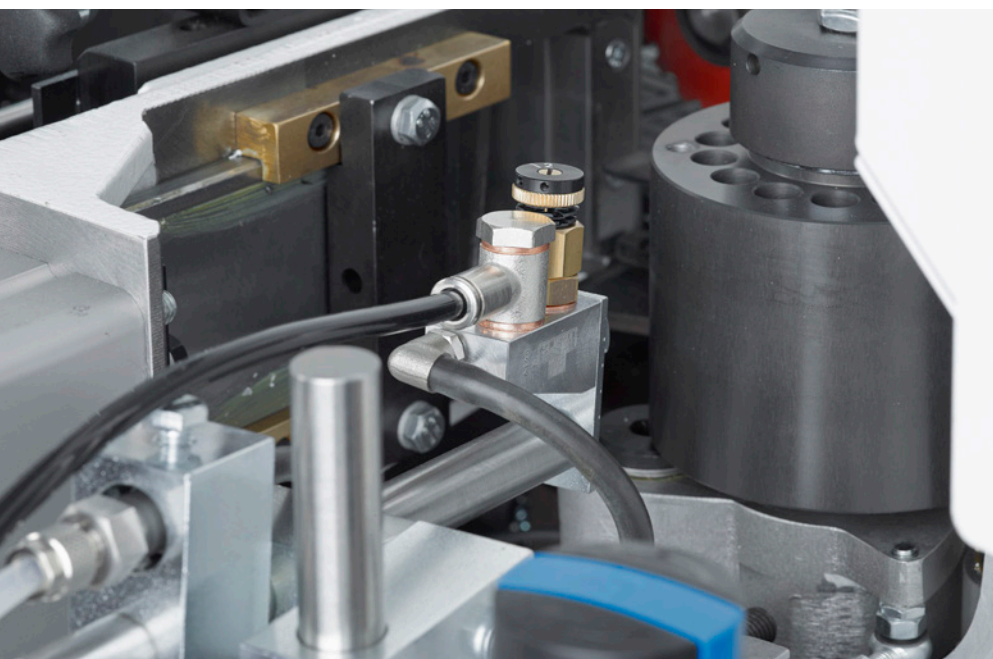

### Spraying device

Spraying agents for optimal processing results, even for sensitive surfaces.

## Joint trimming units

Our joint trimming units form the basis for precise, absolutely straight, and tear-free workpiece edges and glue joints with consistently high product quality.

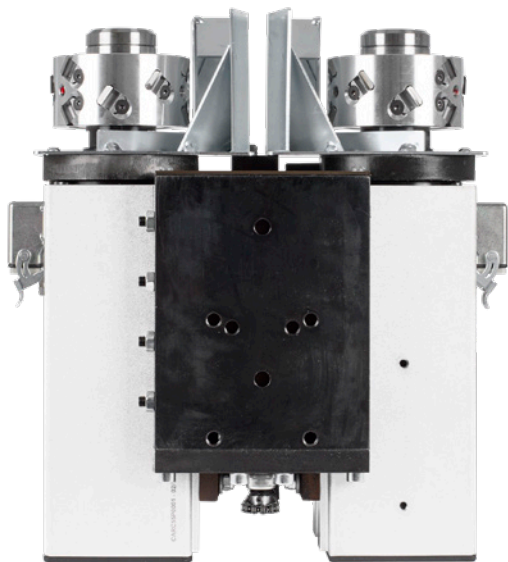

### Joint trimming unit

Diamond tools ensure perfect cutting and a long service life, as well as optimal glue joint quality. The diameter is 100 mm.

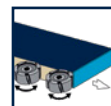

## Gluing units for safe hot-melt glue application

HOMAG gluing units are ideal for quick, solid gluing. The heated gluing roller ensures an optimal adhesive temperature.

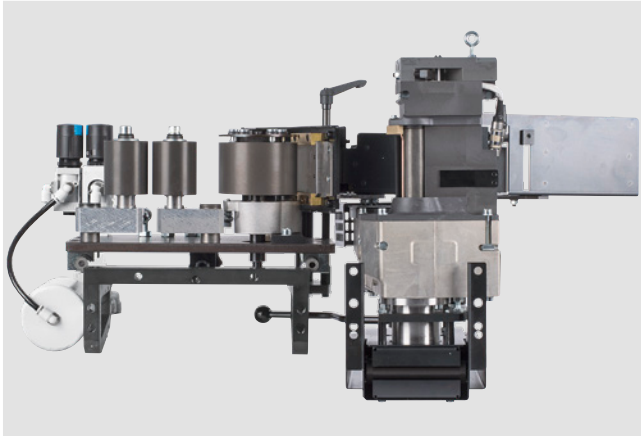

### Gluing units

Quick-change application unit with hot-melt glue supply from below. Can process PUR granulate.

### Your benefits at a glance

- Optimal glue application to narrow surfaces
- Glue application roller does not need to be changed for different workpiece thicknesses
- Gluing roller lifts when feed stops
- Gluing roller with integrated heating unit guarantees a constant temperature and viscosity for all workpiece thicknesses
- Tracing pad prevents wear to the application roller and ensures a constant glue film thickness
- The application unit can be easily removed thanks to the quick-release lock



### Vacuum container

- Compact, portable container for the bottom application unit which is filled with PUR glue.
- No vacuum pump required (Venturi nozzle), as the vacuum is generated via the connection to the compressed air supply in your workshop.
- No nitrogen is necessary due to storage in a vacuum.



## PUR glue and HOMAG – a strong connection

Using polyurethane (PUR) hot-melt glue increases the resistance of furniture to moisture and heat. It is ideal for use on furniture in damp areas such as bathrooms, kitchens and laboratories.



### Your HOMAG PUR benefits at a glance

- One application unit for all types of adhesive
- No additional application unit required
- Fast, powerful thin-film application by means of gluing roller with integrated heating unit
- To be used as standard from the entry-level model to the high-end machine

## Systematic gluing

For solid gluing, it is crucial to achieve an optimum interplay of very different factors. On HOMAG machines, the application

unit, quick-release system, magazine and pressure zone are perfectly aligned.

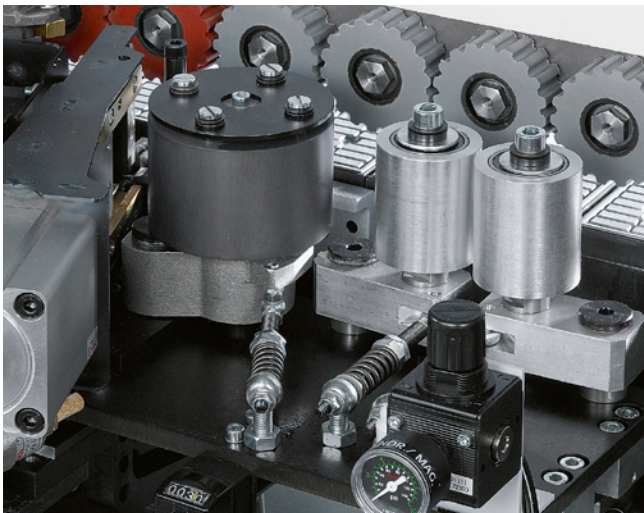

### Pressure zone EDGETEQ S-200

Pressure zone up to an edge thickness of 3 mm and a panel height of 40 mm for optimum glue joint quality.



### Pressure zone EDGETEQ S-200, 1130 FC model

Heavy pressure zone up to 6 mm edge thickness and 60 mm panel height for optimum glue joint quality.



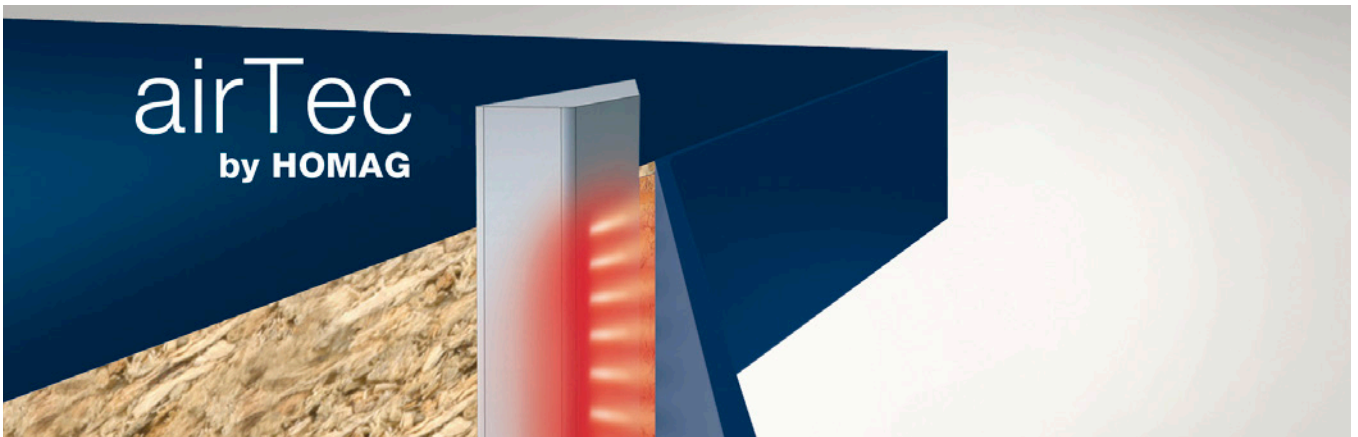

## airTec – an ideal introduction to zero joint technology

The airTec process has established itself as the optimum zero-joint solution for woodworking shops and medium-sized companies. HOMAG's response to increases in demand is an innovative and more efficient airTec solution that ensures

a more cost-effective use of resources. All laser-compatible edging types that are currently available on the market can be processed with airTec. This means great flexibility for all materials and colors.

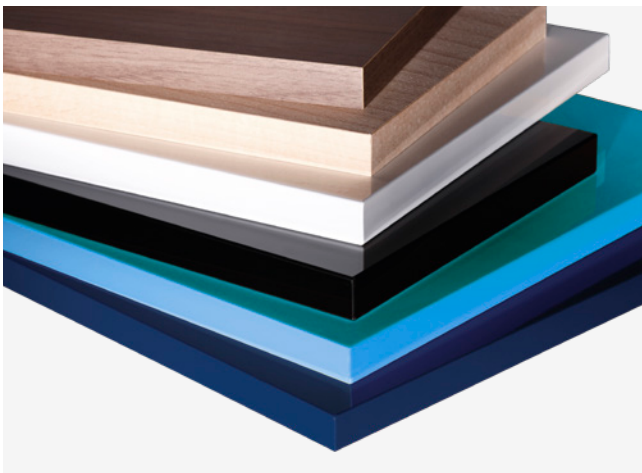

### Gluing edges "without joints"

In the airTec process, the edge and panel are bonded using hot air. This requires the use of special edges. These consist of a decorative layer and a functional layer. Using the HOMAG airTec unit, the functional layer is melted at a constant temperature and volume outflow and optimally applied to the narrow surface.

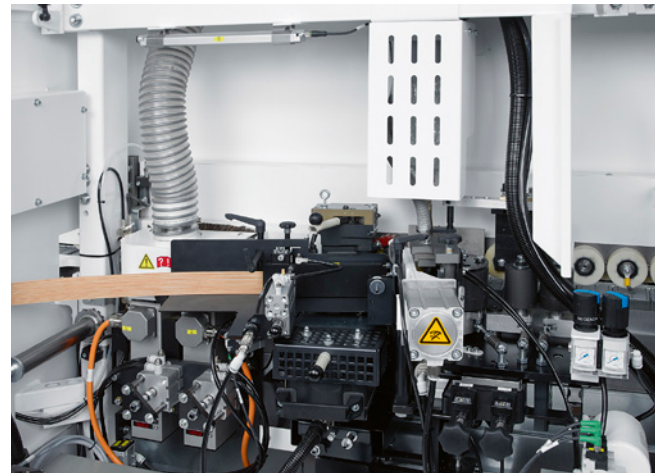

### Easy integration

The airTec reactivation unit is installed in such a way that you can work with either the standard application unit or the airTec system. Image: EDGETEQ S-200, 1110 AT, 1120 AT and 1130 AT. model

## Snipping units for cutting the overhangs on the front sides

The snipping units prepare the workpieces for subsequent trimming perfectly. The front side can be snipped straight or with a chamfer.

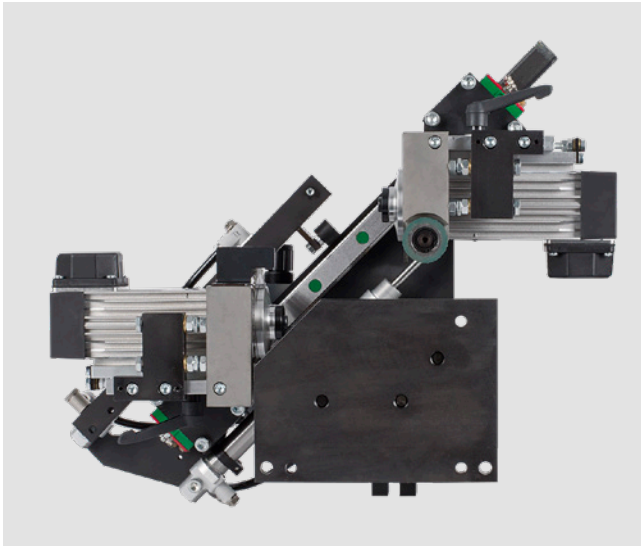

### Snipping unit

Exact snipping cut via a robust snipping unit with a highly precise linear guide.

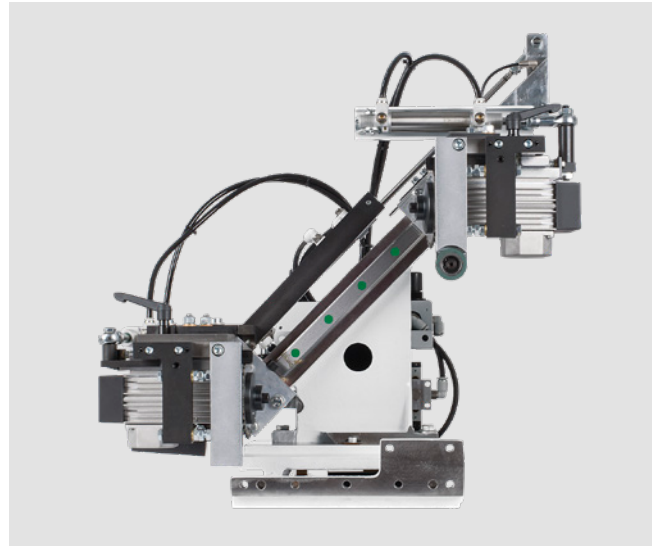

### Snipping unit

Exact snipping cut via a robust snipping unit with a highly precise linear guide. Automatic chamfer/straight adjustment included as standard on the 1130 FC and 1130 AT models.



### Can be automated

For a quick change between flush snipping—e.g. of solid strips or shelves—and cutting with an overhang—e.g. for re-trimming with a profile trimming unit.

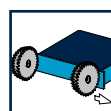
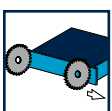

## Trimming units for flush milling

Our fine-milling units offer the perfect solutions for processing edge overhangs. The trimming units are only equipped with tools that collect the chips in a controlled manner.



### Trimming unit

Trimming unit with DFC tool technology (dust flow control) for optimal suction.

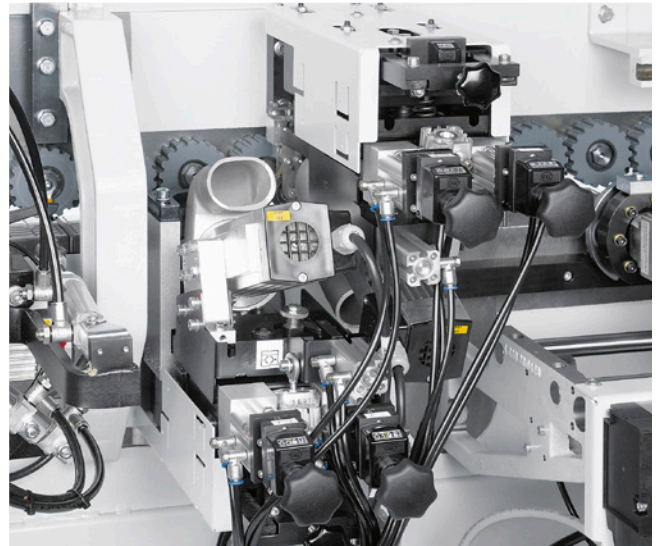

### Trimming unit with pneumatic three-point adjustment (optional)

For more efficient production and significant time savings during changeover.

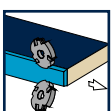

# Profile trimming unit

Unit for rounding the edges on the front and rear edge of the workpiece. The profile trimming unit is an all-rounder. Users can choose between adjusting the unit manually or

electropneumatically. The design is then carried out up to a speed of 8 m/min.

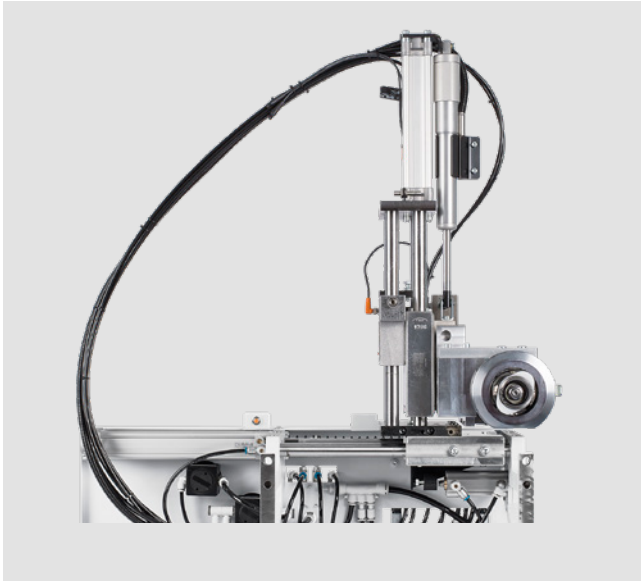

## FF6210 profile trimming unit

Optimum profile trimming without making adjustments thanks to linked DIA tool and detector roller. Equipped with automatic adjustment between thin and thick edges. Workpiece thickness 60 mm.

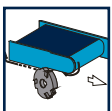

## Structural shelves

Profile trimming is also possible on workpiece sides without an edge. This applies not only to structural shelves, but also to upper and lower shelves, shelf inserts and partition panels.



## Finishing units

With optimally matched finishing units, HOMAG makes the quality of your products perfect.



### Profile scraper unit

Unit for smoothing radii and chamfers. Equipped with changer heads to allow rapid profile changes.

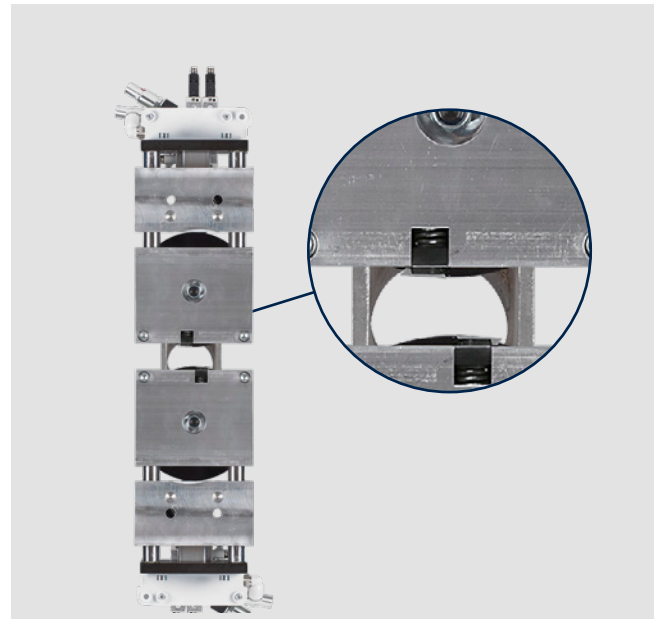
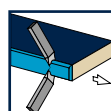
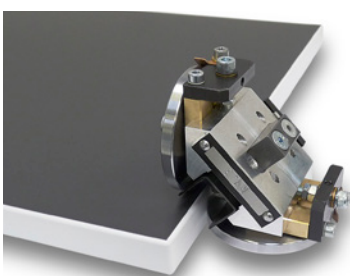

### Glue joint scraping unit

For the perfect finish.

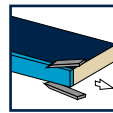

### Buffing unit

For polishing edges for a natural color.

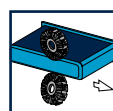

**TECHNISCHE DATEN EDGETEQ S-200 BAUREIHE**

	Modell 1100	Modell 1110 F	Modell 1110 AT	Modell 1120 FC	Modell 1120 AT
<b>Overall length (mm)</b>	3.690	3.690	3.690	4.305	4.305
<b>Feed speed [m/min]</b>	8				
<b>WORKING DIMENSIONS</b>					
<b>Workpiece width (mm) *</b> for workpiece thickness 8–22 mm	70				
<b>Workpiece thickness (mm)</b>	8 – 40				
<b>Edge thickness rollers (mm)</b>	0,3 – 3				
<b>Edge thickness strips/moldings (mm)</b>	0,3 – 3				
* Dependent on the workpiece thickness					

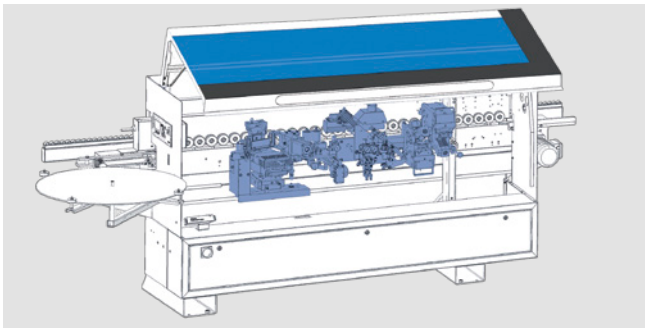

**Model 1100**

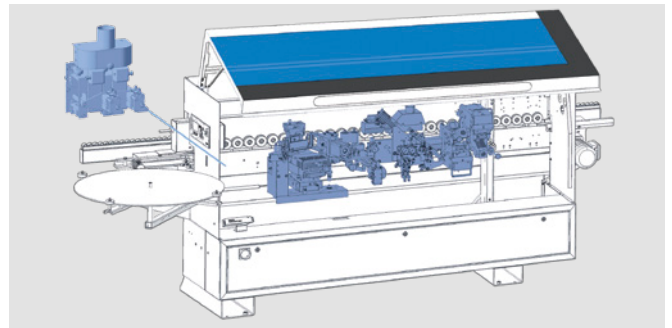

**Model 1110 F**

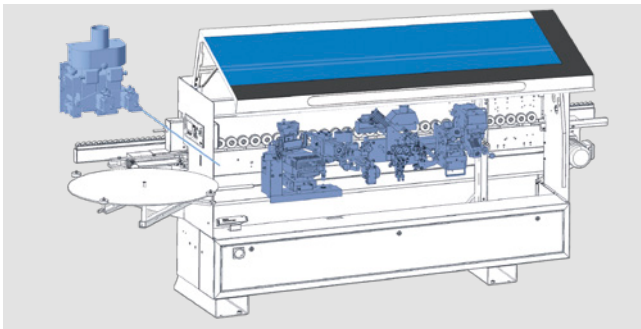

**Model 1110 AT**

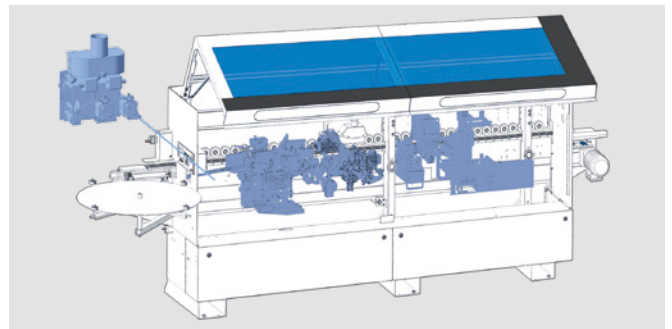

**Modell 1120 FC**

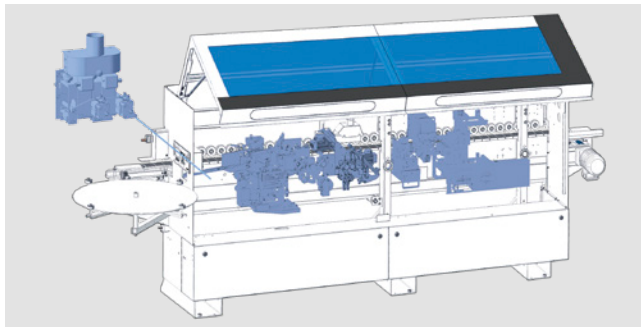

**Modell 1120 AT**

**TECHNICAL DATA OF THE EDGETEQ S-200 SERIES**

	<b>Modell 1130 FC</b>	<b>Modell 1130 AT</b>
<b>Overall length (mm)</b>	4.605	4.605
<b>Feed speed [m/min]</b>	11	8
<b>WORKING DIMENSIONS</b>		
<b>Workpiece width (mm) *</b> for workpiece thickness 8–22 mm	70	
<b>Workpiece thickness (mm)</b>	8 – 60	
<b>Edge thickness rollers (mm)</b>	0,3 – 3	
<b>Edge thickness strips/moldings (mm)</b>	0,3 – 3 (opt. 0,3 – 6)	0,3 – 3

\* Dependent on the workpiece thickness

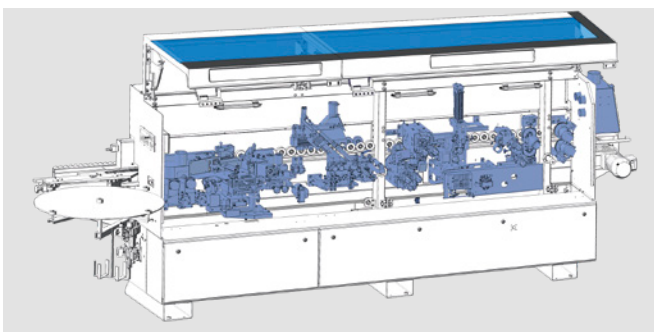

**Modell 1130 FC**

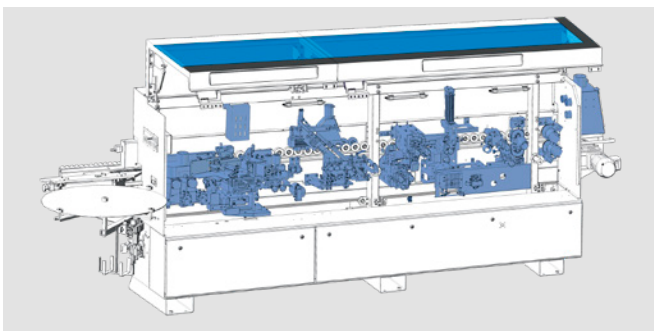

**Modell 1130 AT**





## The right machine for your needs

The machines from the S-200 series offer you comprehensive solutions for manufacturing your products flexibly and economically. Whether living room, bedroom and kitchen furniture, functional office furniture, superior shopfitting solutions or batch size 1 production for

individual requirements — HOMAG offers a well-designed product range to meet any requirement. Using these machines can also make current trends easily achievable for you and your employees.



# VALYOU

Our Mission, Your Performance.

## LIFE CYCLE SERVICES

Improved performance, more efficient processes, faster help, assurance of availability and smarter working

### TEAM & COVERAGE

Largest global service network in the industry with over 1,350 personnel.

### INSTALLATION & COMMISSIONING

For a smooth start, we only let proven experts manage your setup.

### OPERATION & CONTROL

After teaching your personnel the intuitive control system, our clever apps help to make the operator's life much easier.

### MAINTENANCE & SERVICING

To keep things running, we're happy to take a preventative approach. You decide how often and how intensively you want the support to be. As we all know, prevention is better than the cure.

### eSHOP & ONLINE ADVANTAGE

A few clicks and it's fixed. Receive exclusive advantages by ordering spare parts online, depending on market availability. [shop.homag.com](http://shop.homag.com)

### HOTLINE & READINESS

When there's an emergency, we're here. Direct by phone, digitally via app or video, or with on-site support. We are close to you with over 90 regional service organizations worldwide. With more than 35,000 spare parts immediately available, we can deliver 85% of your orders fast.

### TRAINING & EDUCATION

With classroom, live online or eLearning training, we offer flexible options to help you get knowledge. We conduct over 4,000 customer training courses every year, and we even have our own training centers in 19 countries

### MODERNIZATION & IMPROVEMENT

Our modernization program is tailored to your machines and processes. We can evaluate your data and situation and advise you on the next step.

### ANALYSIS & SUSTAINABILITY

On request, we analyze all your processes with proven tools and procedures (LeanSixSigma). We have a large, certified team of experts for this purpose.

### FINANCING & CONSULTING

We offer you tailor-made financing concepts worldwide. With more than 60 years of experience and a close partner network of prominent banks and insurance companies to help us to find the right solution for you, we're always transparent and reliable in processing.

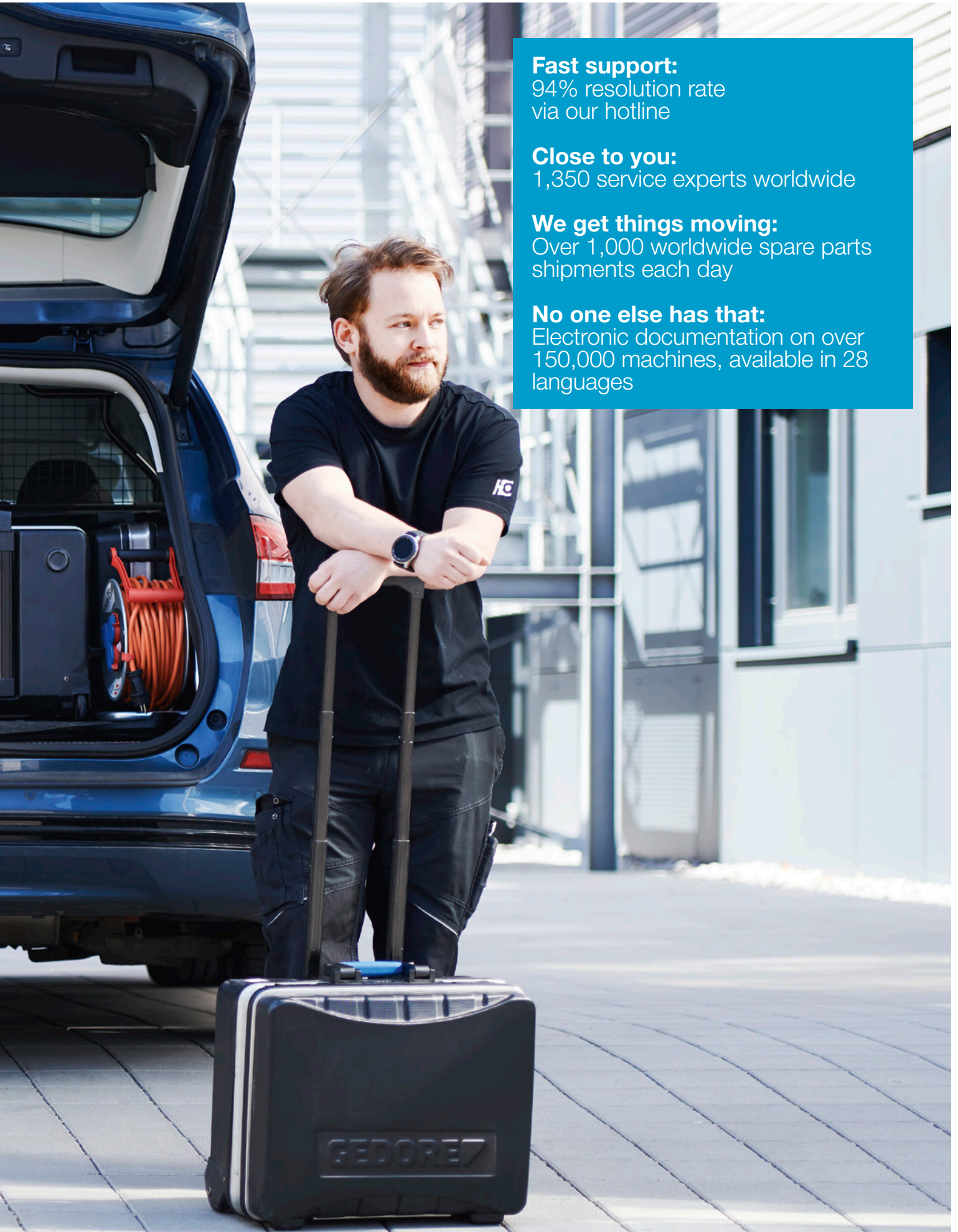

**Fast support:**  
94% resolution rate  
via our hotline

**Close to you:**  
1,350 service experts worldwide

**We get things moving:**  
Over 1,000 worldwide spare parts  
shipments each day

**No one else has that:**  
Electronic documentation on over  
150,000 machines, available in 28  
languages



# HOMAG Group AG

info@homag.com  
www.homag.com

# YOUR SOLUTION